

产品名称:	交流减速电机
型号:	GM48PSMD50375
分类:	梨形交流同步减速电机
用途及说明:	阀门, 咖啡机, 通讯仪器, 自动化产品, 感应垃圾筒, 电子锁具, 光学设备, 医疗器械, 办公设备, 家用电器及各种仪器仪表的驱动及控制。
重量:	约197g

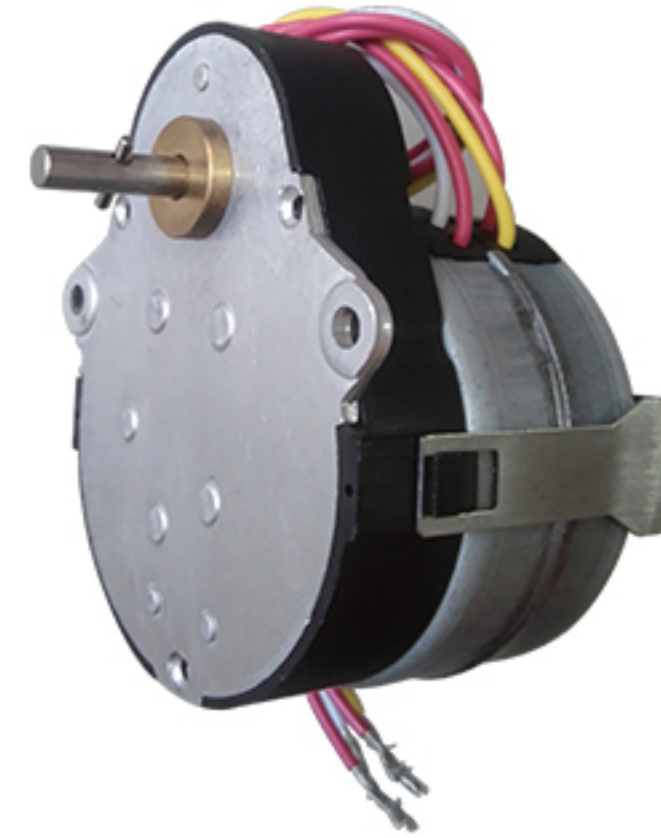

参数 Specifications	单位 UNIT	GM48PSMD50375						
额定电压 Voltage	VAC	24; 110; 230						
频率 Frequency	Hz	50/60						
输入功率 Input	W	<=4W						
电流 Current	A	0.015(230V)						
标准速比 Standard gear ratio		a: 12.5, 15, 25, 41.7(125/3), 83.3(244/3), 164.2, 246.3, 308, 450, 985, 1846.875; (max load: 8kg.cm) b: 34.6, 128.6, 400, 500, 600, 750, 2400, 4500 (max load: 15kg.cm)						
转速 Speed	RPM	1/2	3/4	4.5	9	15	25	30
力矩 Torque	Kg.cm	150	100	16	8	5	3	2.5
噪音 Noise	dB	<=50						
绝缘耐压 Dielectric strength		AC1800V / 1 SEC						
转向 Direction of rotation		双向可控(controllable)						
备注 Note		电压及输出轴可以根据客户要求更改. and output shaft can be changed as customer's request.						Voltage
包装信息 Packing detail		纸箱,尺寸:52X36X36CM; 100台/箱;毛重:23Kg. Carton, Size: 52X36X36CM; 100pcs/carton; G.W:23Kg.						

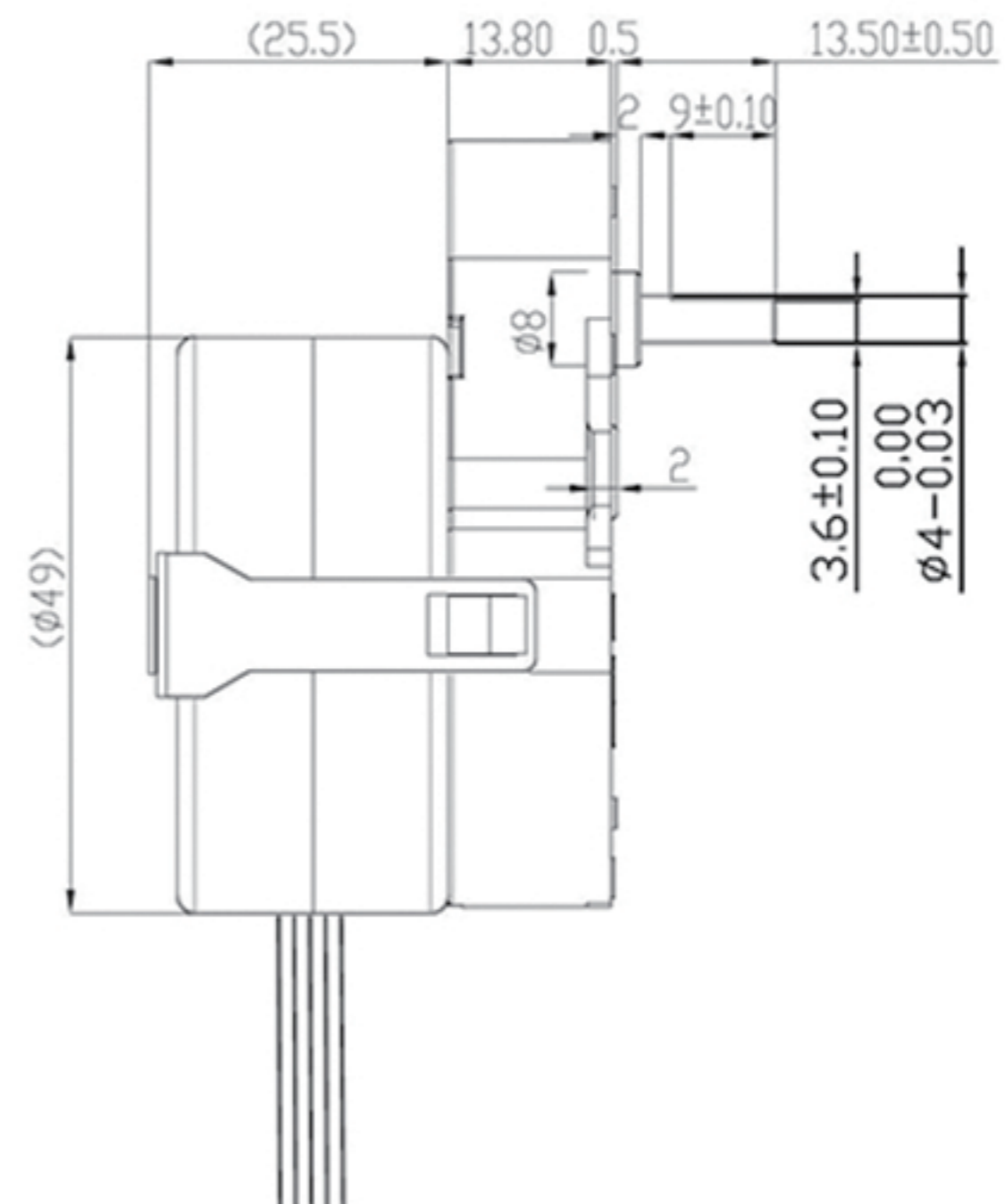
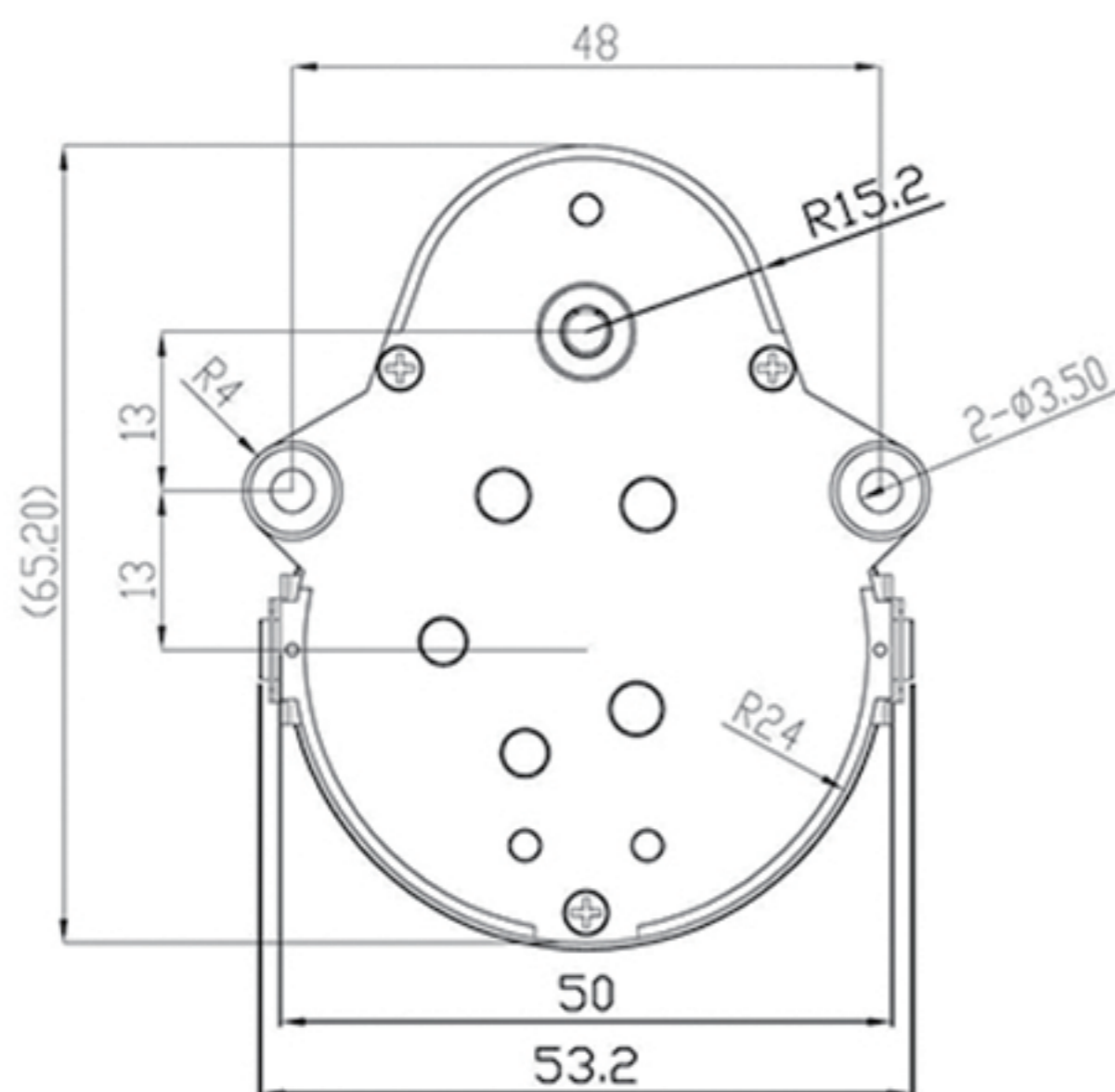

宁波市海曙立诺电器配件有限公司

网址: [www.linomotor.com](http://www.linomotor.com)

邮箱: [sales@linomotor.com](mailto:sales@linomotor.com)